

VG1000 Series Flanged Ball Valves

Product Bulletin

VG1xA5x

Code No. LIT-12011228
Issued July 15, 2008
Supersedes January 26, 2007

The VG1000 Series Flanged Ball Valves are designed primarily to regulate the flow of hot water, chilled water, and 50% glycol solutions to the demand of a controller in Heating, Ventilating, and Air Conditioning (HVAC) systems. The valves come in sizes of 2-1/2, 3, and 4 in. (DN65, DN80, and DN100). These American Society of Mechanical Engineers (ASME) Class 150 flanged valves come in both two- and three-way configurations. Johnson Controls offers valve, linkage, and actuator assemblies for factory or field mounting with either spring return or non-spring return actuators.

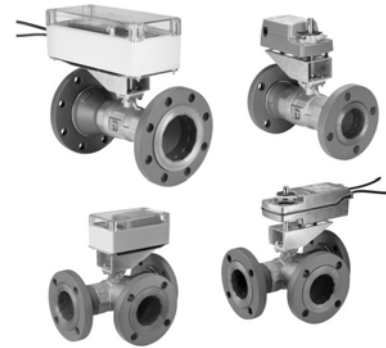

Figure 1: VG1000 Series Ball Valves Shown with Field Mounted M9000 Series Actuators

Table 1: Features and Benefits

Features	Benefits
Closeoff Pressure Rating: <ul style="list-style-type: none"> • 100 psi for Two-Way Valves • 50 psi for Three-Way Valves 	Provides tight shutoff.
300 Stainless Steel Ball and Stem Assembly	Applies to systems with high temperature water (0 to 284°F [-18 to 140°C]) or 25 psi saturated steam.
500:1 Rangeability	Provides accurate control under all load conditions.
Amodel® Flow Characterizing Disk	Provides equal percentage flow characteristics for best temperature control; available in a wide array of Cv ranges to cover a broad variety of applications.
Ethylene Propylene Diene Monomer (EPDM) Double O-Ring Stem Seal	Offers tested leak-free operation for 200,000 cycles in iron-oxide contaminated water.
Graphite-Reinforced Polytetrafluoroethylene (PTFE) Seats	Include 15% graphite-reinforced ball seals that last twice as long in iron-oxide contaminated water when compared to virgin Teflon® ball seats.
PTFE Thermal Spacer	Provides thermal isolation between the actuator and the valve.
Seats Backed with EPDM O-Rings	Maintain a constant seating force that compensates for expansion, contraction, and seat wear without increasing operating torque.
Maintenance-Free Design	Performs without failure in excess of 200,000 full stroke cycles in iron-oxide contaminated water.
Available with Factory-Mounted M9124 or M9220 Series Electric Actuators	Reduces field installation time and cost.
M9000-330 and M9000-340 Weathershields Available for Field Installation	Protect the actuator from corrosion, rain, freezing rain, sleet, and snow.

Ordering Information

Table 2: Ordering Data

V		G		Valve Global																							
1	2	1	3	Product Family										1 = Forged Brass Ball Valve													
	2		4	Body Type and Flow Characteristic										2 = Two-Way, with Equal Percentage Flow Characteristics 8 = Three-Way Mixing with Equal Percentage In-line Port Flow Characteristics and Linear Angle Port Flow Characteristics													
		A	5	Flange Type										A = ASME Class 150													
			5	Trim										5 = Stainless Steel Ball and Stem, 300 Series													
			6	Size and Maximum Cv										Size		Control Disk	Control Port Cv (kv)	Bypass Port Cv (kv) (Three-Way Only)									
		G	7	(kv = [Cv x 0.857])										GS = 2-1/2 in. (DN65)	Yes	47 (40)	29 (25)										
		S	8											GT = 2-1/2 in. (DN65)	Yes	74 (63)	47 (40)										
														GU = 2-1/2 in. (DN65)	Yes	117 (100)	74 (63)										
														HT = 3 in. (DN80)	Yes	74 (63)	47 (40)										
														HU = 3 in. (DN80)	Yes	117 (100)	74 (63)										
														HV = 3 in. (DN80)	Yes	176 (150)	88 (75)										
														HW = 3 in. (DN80)	No	211 (180)	105 (90)										
														JU = 4 in. (DN100)	Yes	117 (100)	74 (63)										
														JV = 4 in. (DN100)	No	176 (150)	88 (75)										
			+	Actuator Mounting										+ = Factory-Mounted Actuator (Leave Fields 9 through 15 blank for valve without factory-mounted actuator)													
			9	9	2	N	Actuator Type (Refer to Actuator Bulletin)										924 = M9124-xGx-2 Non-Spring Return 92N = M9220-xxx-3 Spring Opens 94N = M9220-xxx-3 Spring Closes										
							10	11	12																		
										G	Control Type										A = Floating, AC 24 V or DC 24 V Input B = On/Off G = Proportional: DC 0 (2) to 10 V or 0 (4) to 20 mA with field-furnished 500 ohm resistor						
											13																
												G	Supply Voltage										A = AC 120 V M9220-BAx-3 Only G = AC 24 V				
													14														
														C	Auxiliary Switch										A = No Auxiliary Switch (all Models) Feedback: DC 0(2) to 10 V (M9xxx-GGA Models Only) C = Two Auxiliary Switches Feedback: DC 0(2) to 10 V (M9xxx-GGC Models Only)		
1	2	3	4	5	6	7	8	9	10	11	12	13	14	15	= Field												
V	G	1	2	A	5	G	S	+	9	2	N	G	G	C													
Valve								+ Actuator																			

Example: Ball valve, 2-1/2 in. (DN65), 47 Cv two-way, ASME Class 150 Flange, stainless steel trim, with factory-mounted M9220-GGC-3 actuator, proportional (prop.) control, AC 24 V supply, with feedback and two-way auxiliary switches.

Table 3: Flanged Stainless Steel Trim Ball Valves with Non-Spring Return Electric Actuators

Valve	Size, in.	Cv	Closeoff PSIG	AC 24 V			
				Without Switches		With Two Auxiliary Switches	
				On/Off (Floating)	DC 0 to 10 V Prop.	On/Off (Floating)	DC 0 to 10 V Prop.
				M9124-AGA-2	M9124-GGA-2	M9124-AGC-2	M9124-GGC-2
Two-Way – Non-Spring Return							
VG12A5GS	2-1/2	47	100	VG12A5GS+924AGA	VG12A5GS+924GGA	VG12A5GS+924AGC	VG12A5GS+924GGC
VG12A5GT		74		VG12A5GT+924AGA	VG12A5GT+924GGA	VG12A5GT+924AGC	VG12A5GT+924GGC
VG12A5GU		117		VG12A5GU+924AGA	VG12A5GU+924GGA	VG12A5GU+924AGC	VG12A5GU+924GGC
VG12A5HT	3	74	100	VG12A5HT+924AGA	VG12A5HT+924GGA	VG12A5HT+924AGC	VG12A5HT+924GGC
VG12A5HU		117		VG12A5HU+924AGA	VG12A5HU+924GGA	VG12A5HU+924AGC	VG12A5HU+924GGC
VG12A5HV		176		VG12A5HV+924AGA	VG12A5HV+924GGA	VG12A5HV+924AGC	VG12A5HV+924GGC
VG12A5HW		211		VG12A5HW+924AGA	VG12A5HW+924GGA	VG12A5HW+924AGC	VG12A5HW+924GGC
VG12A5JU	4	117	100	VG12A5JU+924AGA	VG12A5JU+924GGA	VG12A5JU+924AGC	VG12A5JU+924GGC
VG12A5JV		176		VG12A5JV+924AGA	VG12A5JV+924GGA	VG12A5JV+924AGC	VG12A5JV+924GGC
Three-Way – Non-Spring Return							
VG18A5GS	2-1/2	47 / 29	50	VG18A5GS+924AGA	VG18A5GS+924GGA	VG18A5GS+924AGC	VG18A5GS+924GGC
VG18A5GT		74 / 47		VG18A5GT+924AGA	VG18A5GT+924GGA	VG18A5GT+924AGC	VG18A5GT+924GGC
VG18A5GU		117 / 74		VG18A5GU+924AGA	VG18A5GU+924GGA	VG18A5GU+924AGC	VG18A5GU+924GGC
VG18A5HT	3	74 / 47	50	VG18A5HT+924AGA	VG18A5HT+924GGA	VG18A5HT+924AGC	VG18A5HT+924GGC
VG18A5HU		117 / 74		VG18A5HU+924AGA	VG18A5HU+924GGA	VG18A5HU+924AGC	VG18A5HU+924GGC
VG18A5HV		176 / 88		VG18A5HV+924AGA	VG18A5HV+924GGA	VG18A5HV+924AGC	VG18A5HV+924GGC
VG18A5HW		211 / 105		VG18A5HW+924AGA	VG18A5HW+924GGA	VG18A5HW+924AGC	VG18A5HW+924GGC
VG18A5JU	4	117 / 74	50	VG18A5JU+924AGA	VG18A5JU+924GGA	VG18A5JU+924AGC	VG18A5JU+924GGC
VG18A5JV		176 / 88		VG18A5JV+924AGA	VG18A5JV+924GGA	VG18A5JV+924AGC	VG18A5JV+924GGC

Table 4: Flanged Stainless Steel Trim Ball Valves with Spring Return Electric Actuators (Part 1 of 2)

Valve	Size, in.	Cv	Closeoff PSIG	AC 24 V			AC 120 V
				Floating	DC 0 to 10 V Prop.	On/Off	On/Off
				M9220-AGA-3	M9220-GGA-3	M9220-BGA-3	M9220-BAA-3
Two-Way – Spring Return – Valve Open (Normally Open) – without Switches							
VG12A5GS	2-1/2	47	100	VG12A5GS+92NAGA	VG12A5GS+92NGGA	VG12A5GS+92NBGA	VG12A5GS+92NBAA
VG12A5GT		74		VG12A5GT+92NAGA	VG12A5GT+92NGGA	VG12A5GT+92NBGA	VG12A5GT+92NBAA
VG12A5GU		117		VG12A5GU+92NAGA	VG12A5GU+92NGGA	VG12A5GU+92NBGA	VG12A5GU+92NBAA
VG12A5HT	3	74	100	VG12A5HT+92NAGA	VG12A5HT+92NGGA	VG12A5HT+92NBGA	VG12A5HT+92NBAA
VG12A5HU		117		VG12A5HU+92NAGA	VG12A5HU+92NGGA	VG12A5HU+92NBGA	VG12A5HU+92NBAA
VG12A5HV		176		VG12A5HV+92NAGA	VG12A5HV+92NGGA	VG12A5HV+92NBGA	VG12A5HV+92NBAA
VG12A5HW		211		VG12A5HW+92NAGA	VG12A5HW+92NGGA	VG12A5HW+92NBGA	VG12A5HW+92NBAA
VG12A5JU	4	117	100	VG12A5JU+92NAGA	VG12A5JU+92NGGA	VG12A5JU+92NBGA	VG12A5JU+92NBAA
VG12A5JV		176		VG12A5JV+92NAGA	VG12A5JV+92NGGA	VG12A5JV+92NBGA	VG12A5JV+92NBAA

Table 4: Flanged Stainless Steel Trim Ball Valves with Spring Return Electric Actuators (Part 2 of 2)

Valve	Size, in.	Cv	Closeoff PSIG	AC 24 V			AC 120 V
				Floating	DC 0 to 10 V Prop.	On/Off	On/Off
				M9220-AGA-3	M9220-GGA-3	M9220-BGA-3	M9220-BAA-3
Two-Way – Spring Return – Valve Closed (Normally Closed) – without Switches							
VG12A5GS	2-1/2	47	100	VG12A5GS+94NAGA	VG12A5GS+94NGGA	VG12A5GS+94NBGA	VG12A5GS+94NBAA
VG12A5GT		74		VG12A5GT+94NAGA	VG12A5GT+94NGGA	VG12A5GT+94NBGA	VG12A5GT+94NBAA
VG12A5GU		117		VG12A5GU+94NAGA	VG12A5GU+94NGGA	VG12A5GU+94NBGA	VG12A5GU+94NBAA
VG12A5HT	3	74	100	VG12A5HT+94NAGA	VG12A5HT+94NGGA	VG12A5HT+94NBGA	VG12A5HT+94NBAA
VG12A5HU		117		VG12A5HU+94NAGA	VG12A5HU+94NGGA	VG12A5HU+94NBGA	VG12A5HU+94NBAA
VG12A5HV		176		VG12A5HV+94NAGA	VG12A5HV+94NGGA	VG12A5HV+94NBGA	VG12A5HV+94NBAA
VG12A5HW		211		VG12A5HW+94NAGA	VG12A5HW+94NGGA	VG12A5HW+94NBGA	VG12A5HW+94NBAA
VG12A5JU	4	117	100	VG12A5JU+94NAGA	VG12A5JU+94NGGA	VG12A5JU+94NBGA	VG12A5JU+94NBAA
VG12A5JV		176		VG12A5JV+94NAGA	VG12A5JV+94NGGA	VG12A5JV+94NBGA	VG12A5JV+94NBAA
Three-Way – Spring Return Counterclockwise – Port A (Coil) Open to Port AB (Common) – without Switches							
VG18A5GS	2-1/2	47 / 29	50	VG18A5GS+92NAGA	VG18A5GS+92NGGA	VG18A5GS+92NBGA	VG18A5GS+92NBAA
VG18A5GT		74 / 47		VG18A5GT+92NAGA	VG18A5GT+92NGGA	VG18A5GT+92NBGA	VG18A5GT+92NBAA
VG18A5GU		117 / 74		VG18A5GU+92NAGA	VG18A5GU+92NGGA	VG18A5GU+92NBGA	VG18A5GU+92NBAA
VG18A5HT	3	74 / 47	50	VG18A5HT+92NAGA	VG18A5HT+92NGGA	VG18A5HT+92NBGA	VG18A5HT+92NBAA
VG18A5HU		117 / 74		VG18A5HU+92NAGA	VG18A5HU+92NGGA	VG18A5HU+92NBGA	VG18A5HU+92NBAA
VG18A5HV		176 / 88		VG18A5HV+92NAGA	VG18A5HV+92NGGA	VG18A5HV+92NBGA	VG18A5HV+92NBAA
VG18A5HW		211 / 105		VG18A5HW+92NAGA	VG18A5HW+92NGGA	VG18A5HW+92NBGA	VG18A5HW+92NBAA
VG18A5JU	4	117 / 74	50	VG18A5JU+92NAGA	VG18A5JU+92NGGA	VG18A5JU+92NBGA	VG18A5JU+92NBAA
VG18A5JV		176 / 88		VG18A5JV+92NAGA	VG18A5JV+92NGGA	VG18A5JV+92NBGA	VG18A5JV+92NBAA
Three-Way – Spring Return Clockwise – Port B (Bypass) Open to Port AB (Common) – without Switches							
VG18A5GS	2-1/2	47 / 29	50	VG18A5GS+94NAGA	VG18A5GS+94NGGA	VG18A5GS+94NBGA	VG18A5GS+94NBAA
VG18A5GT		74 / 47		VG18A5GT+94NAGA	VG18A5GT+94NGGA	VG18A5GT+94NBGA	VG18A5GT+94NBAA
VG18A5GU		117 / 74		VG18A5GU+94NAGA	VG18A5GU+94NGGA	VG18A5GU+94NBGA	VG18A5GU+94NBAA
VG18A5HT	3	74 / 47	50	VG18A5HT+94NAGA	VG18A5HT+94NGGA	VG18A5HT+94NBGA	VG18A5HT+94NBAA
VG18A5HU		117 / 74		VG18A5HU+94NAGA	VG18A5HU+94NGGA	VG18A5HU+94NBGA	VG18A5HU+94NBAA
VG18A5HV		176 / 88		VG18A5HV+94NAGA	VG18A5HV+94NGGA	VG18A5HV+94NBGA	VG18A5HV+94NBAA
VG18A5HW		211 / 105		VG18A5HW+94NAGA	VG18A5HW+94NGGA	VG18A5HW+94NBGA	VG18A5HW+94NBAA
VG18A5JU	4	117 / 74	50	VG18A5JU+94NAGA	VG18A5JU+94NGGA	VG18A5JU+94NBGA	VG18A5JU+94NBAA
VG18A5JV		176 / 88		VG18A5JV+94NAGA	VG18A5JV+94NGGA	VG18A5JV+94NBGA	VG18A5JV+94NBAA

Table 5: Flanged Stainless Steel Trim Ball Valves with Spring Return Electric Actuators with Two Switches (Part 1 of 2)

Valve	Size, in.	Cv	Closeoff PSIG	AC 24 V			AC 120 V
				Floating	DC 0 to 10 V Prop.	On/Off	On/Off
				M9220-AGC-3	M9220-GGC-3	M9220-BGC-3	M9220-BAC-3
Two-Way – Spring Return – Valve Open (Normally Open) – with Two Auxiliary Switches							
VG12A5GS	2-1/2	47	100	VG12A5GS+92NAGC	VG12A5GS+92NGGC	VG12A5GS+92NBGC	VG12A5GS+92NBAC
VG12A5GT		74		VG12A5GT+92NAGC	VG12A5GT+92NGGC	VG12A5GT+92NBGC	VG12A5GT+92NBAC
VG12A5GU		117		VG12A5GU+92NAGC	VG12A5GU+92NGGC	VG12A5GU+92NBGC	VG12A5GU+92NBAC
VG12A5HT	3	74	100	VG12A5HT+92NAGC	VG12A5HT+92NGGC	VG12A5HT+92NBGC	VG12A5HT+92NBAC
VG12A5HU		117		VG12A5HU+92NAGC	VG12A5HU+92NGGC	VG12A5HU+92NBGC	VG12A5HU+92NBAC
VG12A5HV		176		VG12A5HV+92NAGC	VG12A5HV+92NGGC	VG12A5HV+92NBGC	VG12A5HV+92NBAC
VG12A5HW		211		VG12A5HW+92NAGC	VG12A5HW+92NGGC	VG12A5HW+92NBGC	VG12A5HW+92NBAC
VG12A5JU	4	117	100	VG12A5JU+92NAGC	VG12A5JU+92NGGC	VG12A5JU+92NBGC	VG12A5JU+92NBAC
VG12A5JV		176		VG12A5JV+92NAGC	VG12A5JV+92NGGC	VG12A5JV+92NBGC	VG12A5JV+92NBAC
Two-Way – Spring Return – Valve Closed (Normally Closed) – with Two Auxiliary Switches							
VG12A5GS	2-1/2	47	100	VG12A5GS+94NAGC	VG12A5GS+94NGGC	VG12A5GS+94NBGC	VG12A5GS+94NBAC
VG12A5GT		74		VG12A5GT+94NAGC	VG12A5GT+94NGGC	VG12A5GT+94NBGC	VG12A5GT+94NBAC
VG12A5GU		117		VG12A5GU+94NAGC	VG12A5GU+94NGGC	VG12A5GU+94NBGC	VG12A5GU+94NBAC
VG12A5HT	3	74	100	VG12A5HT+94NAGC	VG12A5HT+94NGGC	VG12A5HT+94NBGC	VG12A5HT+94NBAC
VG12A5HU		117		VG12A5HU+94NAGC	VG12A5HU+94NGGC	VG12A5HU+94NBGC	VG12A5HU+94NBAC
VG12A5HV		176		VG12A5HV+94NAGC	VG12A5HV+94NGGC	VG12A5HV+94NBGC	VG12A5HV+94NBAC
VG12A5HW		211		VG12A5HW+94NAGC	VG12A5HW+94NGGC	VG12A5HW+94NBGC	VG12A5HW+94NBAC
VG12A5JU	4	117	100	VG12A5JU+94NAGC	VG12A5JU+94NGGC	VG12A5JU+94NBGC	VG12A5JU+94NBAC
VG12A5JV		176		VG12A5JV+94NAGC	VG12A5JV+94NGGC	VG12A5JV+94NBGC	VG12A5JV+94NBAC
Three-Way – Spring Return Counterclockwise – Port A (Coil) Open to Port AB (Common) – with Two Auxiliary Switches							
VG18A5GS	2-1/2	47 / 29	50	VG18A5GS+92NAGC	VG18A5GS+92NGGC	VG18A5GS+92NBGC	VG18A5GS+92NBAC
VG18A5GT		74 / 47		VG18A5GT+92NAGC	VG18A5GT+92NGGC	VG18A5GT+92NBGC	VG18A5GT+92NBAC
VG18A5GU		117 / 74		VG18A5GU+92NAGC	VG18A5GU+92NGGC	VG18A5GU+92NBGC	VG18A5GU+92NBAC
VG18A5HT	3	74 / 47	50	VG18A5HT+92NAGC	VG18A5HT+92NGGC	VG18A5HT+92NBGC	VG18A5HT+92NBAC
VG18A5HU		117 / 74		VG18A5HU+92NAGC	VG18A5HU+92NGGC	VG18A5HU+92NBGC	VG18A5HU+92NBAC
VG18A5HV		176 / 88		VG18A5HV+92NAGC	VG18A5HV+92NGGC	VG18A5HV+92NBGC	VG18A5HV+92NBAC
VG18A5HW		211 / 105		VG18A5HW+92NAGC	VG18A5HW+92NGGC	VG18A5HW+92NBGC	VG18A5HW+92NBAC
VG18A5JU	4	117 / 74	50	VG18A5JU+92NAGC	VG18A5JU+92NGGC	VG18A5JU+92NBGC	VG18A5JU+92NBAC
VG18A5JV		176 / 88		VG18A5JV+92NAGC	VG18A5JV+92NGGC	VG18A5JV+92NBGC	VG18A5JV+92NBAC
Three-Way – Spring Return Clockwise – Port B (Bypass) Open to Port AB (Common) – with Two Auxiliary Switches							
VG18A5GS	2-1/2	47 / 29	50	VG18A5GS+94NAGC	VG18A5GS+94NGGC	VG18A5GS+94NBGC	VG18A5GS+94NBAC
VG18A5GT		74 / 47		VG18A5GT+94NAGC	VG18A5GT+94NGGC	VG18A5GT+94NBGC	VG18A5GT+94NBAC
VG18A5GU		117 / 74		VG18A5GU+94NAGC	VG18A5GU+94NGGC	VG18A5GU+94NBGC	VG18A5GU+94NBAC

Table 5: Flanged Stainless Steel Trim Ball Valves with Spring Return Electric Actuators with Two Switches (Part 2 of 2)

Valve	Size, in.	Cv	Closeoff PSIG	AC 24 V			AC 120 V
				Floating	DC 0 to 10 V Prop.	On/Off	On/Off
				M9220-AGC-3	M9220-GGC-3	M9220-BGC-3	M9220-BAC-3
VG18A5HT	3	74 / 47	50	VG18A5HT+94NAGC	VG18A5HT+94NGGC	VG18A5HT+94NBGC	VG18A5HT+94NBAC
VG18A5HU		117 / 74		VG18A5HU+94NAGC	VG18A5HU+94NGGC	VG18A5HU+94NBGC	VG18A5HU+94NBAC
VG18A5HV		176 / 88		VG18A5HV+94NAGC	VG18A5HV+94NGGC	VG18A5HV+94NBGC	VG18A5HV+94NBAC
VG18A5HW		211 / 105		VG18A5HW+94NAGC	VG18A5HW+94NGGC	VG18A5HW+94NBGC	VG18A5HW+94NBAC
VG18A5JU	4	117 / 74	50	VG18A5JU+94NAGC	VG18A5JU+94NGGC	VG18A5JU+94NBGC	VG18A5JU+94NBAC
VG18A5JV		176 / 88		VG18A5JV+94NAGC	VG18A5JV+94NGGC	VG18A5JV+94NBGC	VG18A5JV+94NBAC

Table 6: Shipping Weights, lb (kg)¹

Valve Code Number	Description	Shipping Weight, lb (kg)
VG12A5Gx	2-1/2 in. (DN65) Two-Way Flanged Ball Valve, ASME 150 Flanged End Connections	34 (15.4)
VG12A5Hx	3 in. (DN80) Two-Way Flanged Ball Valve, ASME 150 Flanged End Connections	36 (16.3)
VG12A5Jx	4 in. (DN100) Two-Way Flanged Ball Valve, ASME 150 Flanged End Connections	44 (20.0)
VG18A5Gx	2-1/2 in. (DN65) Three-Way Flanged Ball Valve, ASME 150 Flanged End Connections	43 (19.5)
VG18A5Hx	3 in. (DN80) Three-Way Flanged Ball Valve, ASME 150 Flanged End Connections	49 (22.2)
VG18A5Jx	4 in. (DN100) Three-Way Flanged Ball Valve, ASME 150 Flanged End Connections	62 (28.1)

1. For M9100 actuated non-spring return valve assemblies, add 4.4 lb (2.0 kg); for M9220 actuated valve assemblies, add 9.1 lb (4.1 kg).

Table 7: Valid Ball Valve, Electric Actuator, Linkage, and Weathershield Combinations (for Field Assembly)

Valve Size, in. (DN)	Valve Code Number	Actuator Base Number	Link Kit Code Number	Optional Weathershield Code Number
2-1/2 (DN65)	VG12A5Gx, VG18A5Gx	M9124	M9000-518	M9000-330
		M9220	M9000-519	M9000-340
3 (DN80)	VG12A5Hx, VG18A5Hx	M9124	M9000-518	M9000-330
		M9220	M9000-519	M9000-340
4 (DN100)	VG12A5Jx, VG18A5Jx	M9124	M9000-518	M9000-330
		M9220	M9000-519	M9000-340

Product Details

Available in sizes 2-1/2 to 4 in. (DN65 to DN100), VG1000 Series Flanged Ball Valves are designed specifically for automated commercial HVAC service. These valves feature a 300 Series stainless steel ball and stem for high temperature water to 284°F (140°C) and saturated steam to 25 psi.

The stem and mounting flange, combined with an innovative double O-ring stem seal, provide quick and easy electric actuator field mounting while ensuring long life and leak-free valve performance. The specially engineered, graphite-reinforced PTFE seat with flexible PTFE seat design (backed with EPDM O-rings) significantly reduces the operating torque, allowing the smallest possible electric actuator available to provide the force required for each specific application.

Two-Way valve assemblies provide 100 psig (689 kPa), and three-way assemblies provide 50 psi (345 kPa) closeoff pressure while ensuring operation after long idle periods.

VG1000 Series Flanged Ball Valves are designed for factory or field mounting to Johnson Controls® M9124 Non-Spring Return and M9220 Spring Return Series Electric Actuators, which are ideally suited for on/off, floating, or proportional HVAC service. To field-couple an actuator to a valve, use an M9000-518 Linkage Kit for M9124 actuators or an M9000-519 Linkage Kit for M9220 actuators. The cost-effective, reliable design makes the VG1000 Series Ball Valves maintenance-free.

IMPORTANT: The VG1000 Series Valves are intended to control saturated steam, hot water, and chilled water flow under normal equipment operating conditions. Where failure or malfunction of the valve could lead to personal injury or property damage to the controlled equipment or other property, additional precautions must be designed into the system. Incorporate and maintain other devices such as supervisory or alarm systems or safety or limit controls intended to warn of, or protect against, failure or malfunction of the valve.

Electric Actuator Control Signal Action

Two-way VG1000 Series Ball Valves are fully open when the electric actuator is fully Counterclockwise (CCW) and fully closed when the electric actuator is fully Clockwise (CW).

For three-way valves, Coil Port A and Common Port AB are fully open when the electric actuator is fully CCW, as shown in Figure 2. Bypass Port B and Common Port AB are fully open when the actuator is fully CW, as shown in Figure 3.

For non-spring return and spring-to-open proportional control models in the direct-acting mode, a minimum control signal drives the electric actuator to the fully CCW position, while a maximum control signal drives the electric actuator to the fully CW position.

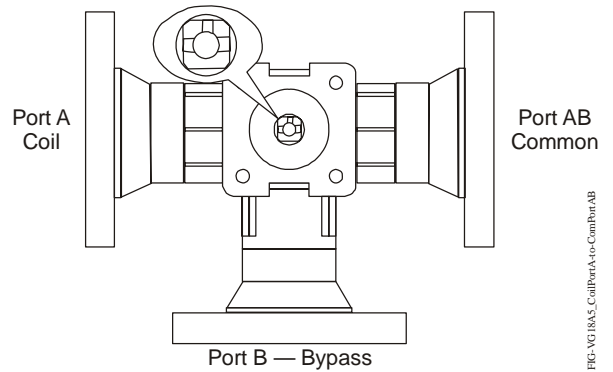

Figure 2: VG18A5 Series Three-Way Ball Valve (Coil Port A Open to Common Port AB)

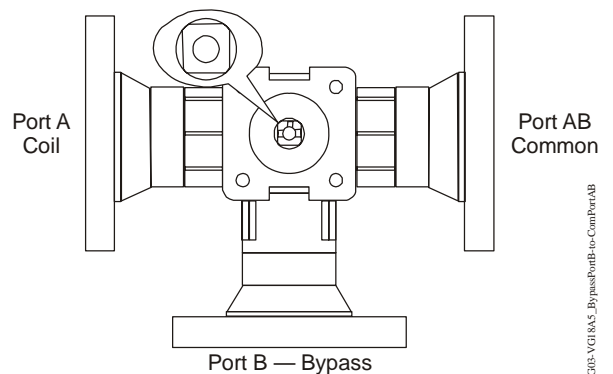

Figure 3: VG18A5 Series Three-Way Ball Valve (Bypass Port B Open to Common Port AB)

For spring-to-close proportional control models in the direct-acting mode, a minimum control signal drives the electric actuator to the fully CW position, whereas a maximum control signal drives the electric actuator to the fully CCW position. For more information on these electric actuator series, as well as details on models available, refer to the following documentation:

- *M9108, M9116, M9124, and M9132 Series Electric Non-spring Return Actuators Product Bulletin (LIT-2681058)*
- *M9220-xxx-3 Electric Spring Return Actuators Product Bulletin (LIT-12011057)*

Repair Information

If the VG1000 Series Flanged Ball Valve fails to operate within its specifications, replace the unit. For a replacement valve, contact the nearest Johnson Controls representative.

Piping

See Figure 4 for typical piping configurations:

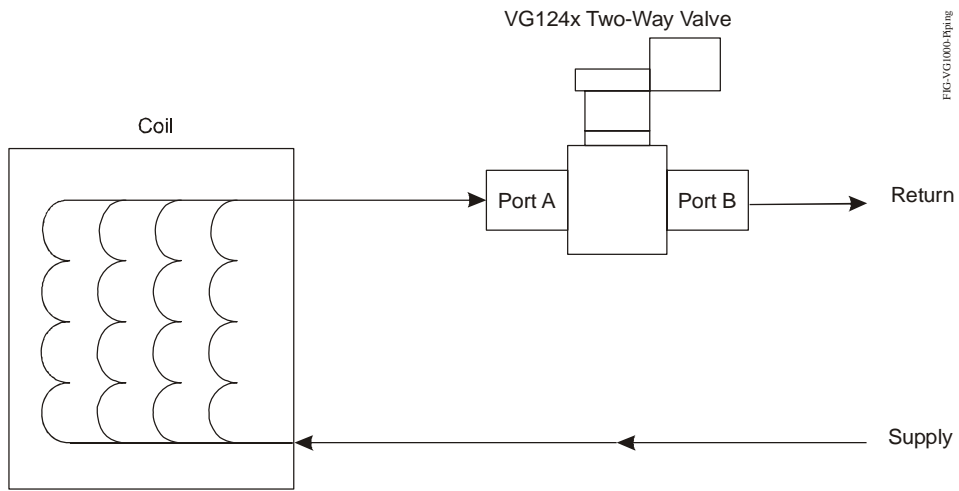

FIG-VG1000-Piping

Typical Two-Way Ball Valve Application

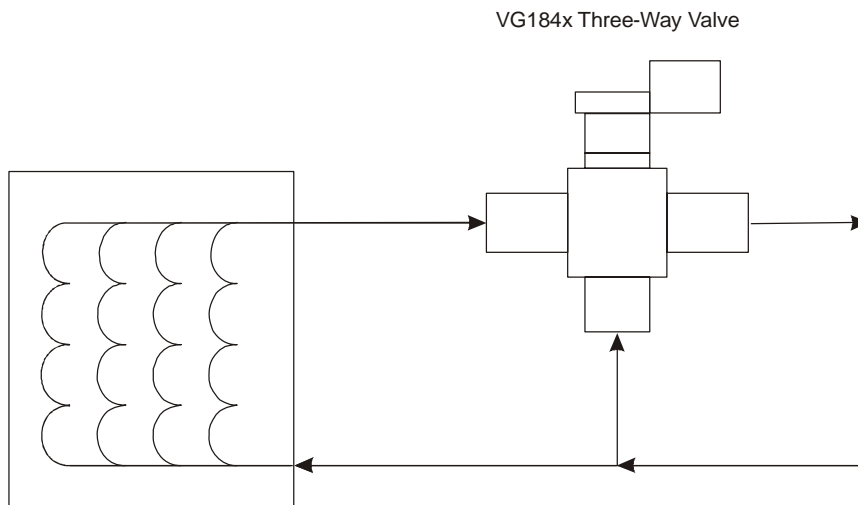

Figure 4: Typical VG1000 Series Flanged Ball Valve Piping Application

Note: Mount the valve downstream from the coil to minimize heat transfer to the actuator.

Dimensions

Figure 5 depicts VG12A5xx Two-Way Series Flanged Ball Valves combined with the M9124 Series Actuators, identifying the dimensions listed in Table 8. See Figure 6 for corresponding information for the VG18A5xx Three-Way Series Flanged Ball Valves combined with the M9124 Series Actuators.

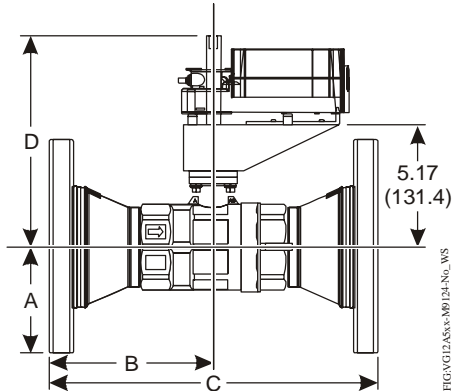

Figure 5: M9124 Series Actuated VG12A5xx Two-Way Series Ball Valves, in. (mm)

Figure 7 depicts VG12A5xx Two-Way Series Flanged Ball Valves combined with the M9220 Series Actuators, identifying the dimensions listed in Table 8. See Figure 8 for corresponding information for the VG18A5xx Three-Way Series Flanged Ball Valves combined with the M9220 Series Actuators.

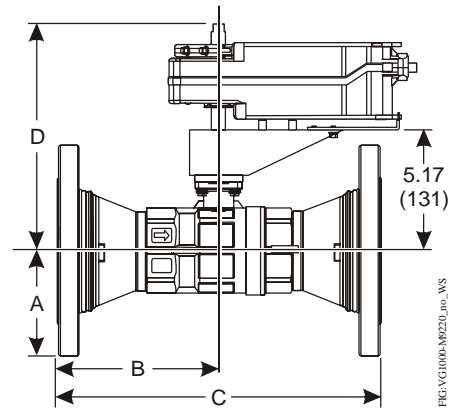

Figure 7: M9220 Series Actuated VG12A5xx Two-Way Series Ball Valves, in. (mm)

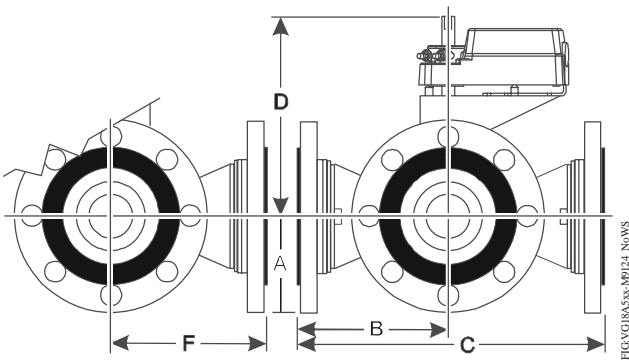

Figure 6: M9124 Series Actuated VG18A5xx Three-Way Series Ball Valves

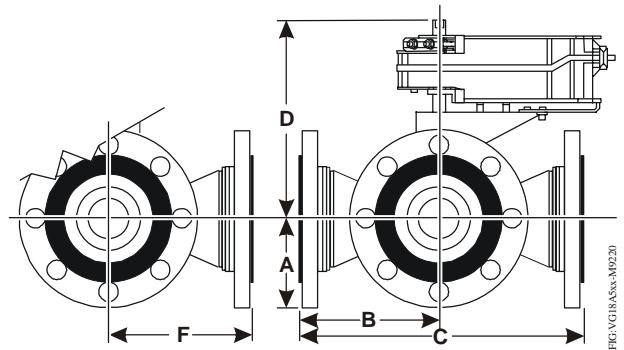

Figure 8: M9220 Series Actuated VG18A5xx Three-Way Series Ball Valves

Table 8: VG1xA5xx Series Ball Valves Dimensions, in. (mm)

Valve Size in. (DN)	A	B	C	D		F
				M9124 ¹	M9220 ¹	
2-1/2 (DN65)	3.50 (89)	5.71 (145)	11.42 (290)	8.89 (226)	9.64 (245)	5.87 (149)
3 (DN80)	3.75 (95)	6.10 (155)	12.20 (310)			6.26 (159)
4 (DN100)	4.50 (114)	6.89 (175)	13.77 (350)			7.05 (179)

1. Allow a minimum of 4 in. clearance above the shaft to remove the actuator.

Figure 9 depicts VG12A5xx Two-Way Series Flanged Ball Valves combined with the M9124 Series Non-Spring Return Actuators, identifying the dimensions listed in Table 9. See Figure 10 for corresponding information for the VG18A5xx Three-Way Series Flanged Ball Valves combined with the M9124 Series Non-Spring Return Actuators. Each drawing includes dimensions for the field-installed M9000-330 Weathershield.

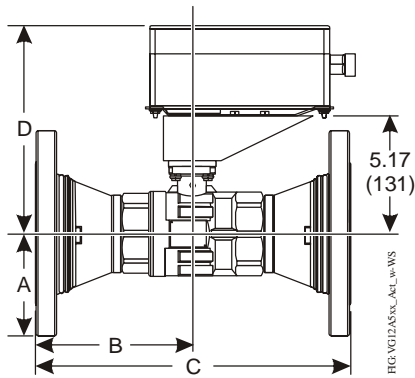

Figure 9: M9124 Series Actuated VG12A5xx Two-Way Series Ball Valves with M9000-330 Weathershield Dimensions, in. (mm)

Figure 11 depicts VG12A5xx Two-Way Series Flanged Ball Valves combined with the M9220 Series Spring Return Actuators identifying the dimensions listed in Table 9. See Figure 12 for corresponding information for the VG18A5xx Three-Way Series Flanged Ball Valves combined with the M9220 Series Spring Return Actuators dimensions. Each drawing includes dimensions for the field-installed M9000-340 Weathershield.

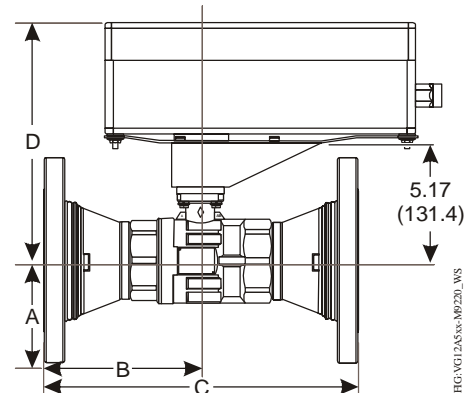

Figure 11: M9220 Series Actuated VG12A5xx Two-Way Series Ball Valves with M9000-340 Weathershield Dimensions, in. (mm)

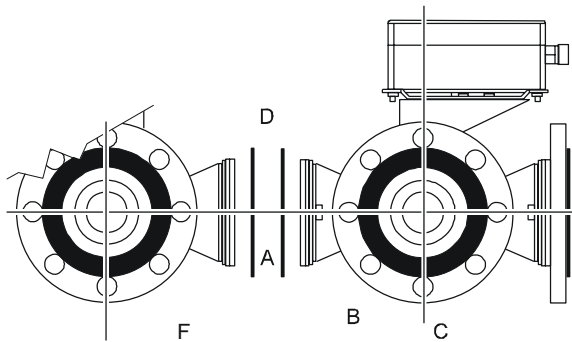

Figure 10: M9124 Series Actuated VG18A5xx Three-Way Series Ball Valves with M9000-330 Weathershield

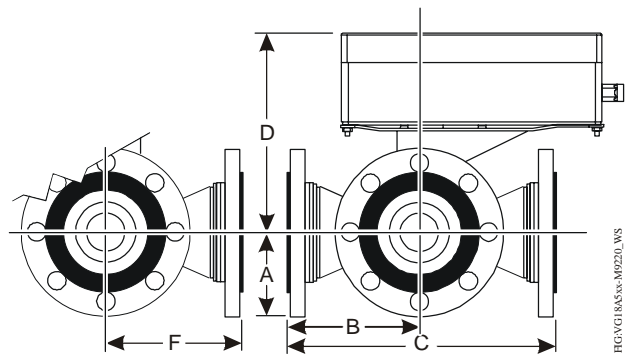

Figure 12: M9220 Series Actuated VG18A5xx Three-Way Series Ball Valves with M9000-340 Weathershield

Table 9: VG12A5x and VG18A5xx Ball Valves with Weathershield Dimensions, in. (mm)

Valve Size in (DN)	A	B	C	D		F
				M9124	M9220	
2-1/2 (DN65)	3.50 (89)	5.71 (145)	11.42 (290)	9.07 (230)	10.25 (260)	5.87 (149)
3 (DN80)	3.75 (95)	6.10 (155)	12.20 (310)			6.26 (159)
4 (DN100)	4.50 (114)	6.89 (175)	13.77 (350)			7.05 (179)

Technical Specifications

VG1000 Series Flanged Ball Valves

Service¹		Hot Water, Chilled Water, 50/50 Glycol Solutions, and 25 psig (172 kPa) Saturated Steam for HVAC Systems
Valve Fluid Temperature Limits		0 to 284°F (-18 to 140°C)
Valve Body Pressure/ Temperature Rating	Water	ASME Class 150 250 psi at -20 to 100°F (29 to 38°C) 235 psi at: 200°F(93°C) 218 psi at: 284°F(140°C)
	Steam	25 psig (172 kPa) Saturated Steam for HVAC Systems
Maximum Closeoff Pressure	Two-Way	100 psi (689 kPa)
	Three-Way	50 psi (345 kPa)
Maximum Recommended Operating Pressure Drop		30 psi (207 kPa) for quiet service
Flow Characteristics	Two-Way	Equal Percentage
	Three-Way	Equal Percentage Flow Characteristics of In-line Port or Linear Percentage Flow Characteristics of Angle Port
Rangeability²		Greater than 500:1
Leakage	Two- or Three-Way	0.01% of Maximum Flow, Control Port, ANSI/FCI 70-2, Class 4
	Three-Way	1% of Maximum Flow, Bypass Port
End Connections		ASME Class 150 Flange
Minimum Ambient Operating Temperature	-4°F (-20°C)	M9124 Series Non-Spring Return Actuators
	-40°F (-40°C)	M9220 Series Spring Return Actuators
Maximum Ambient Operating Temperature³	122°F (50°C)	M9124 Series Non-Spring Return Actuators
	131°F (55°C)	M9220 Series Spring Return Actuators
Materials	Body	Brass
	Flanges	Ductile Iron
	Ball	300 Series Stainless Steel
	Stem	300 Series Stainless Steel
	Seats	Graphite Reinforced PTFE with EPDM O-Ring Backing
	Stem Seals	EPDM O-Rings
	Flow Control Disk	Amodel AS-1145HS Polyphthalamide Resin

1. Refer to VDI 2035 Standard for proper water treatment.
2. Rangeability is defined as the ratio of maximum controllable flow to minimum controllable flow.
3. In steam applications, install the valve with the stem horizontal to the piping and wrap the valve and piping with insulation.

The performance specifications are nominal and conform to acceptable industry standards. For application at conditions beyond these specifications, consult the local Johnson Controls office. Johnson Controls, Inc. shall not be liable for damages resulting from misapplication or misuse of its products.



Building Efficiency
507 E. Michigan Street, Milwaukee, WI 53202

Metasys® and Johnson Controls® are registered trademarks of Johnson Controls, Inc. All other marks herein are the marks of their respective owners. © 2008 Johnson Controls, Inc.